

SCHALTPLAN



KBS Gastrotechnik GmbH – Schoßbergstraße 26 – 65201 Wiesbaden

YSD-8AS

AC/L.N/230V/50-60Hz/6.4kW

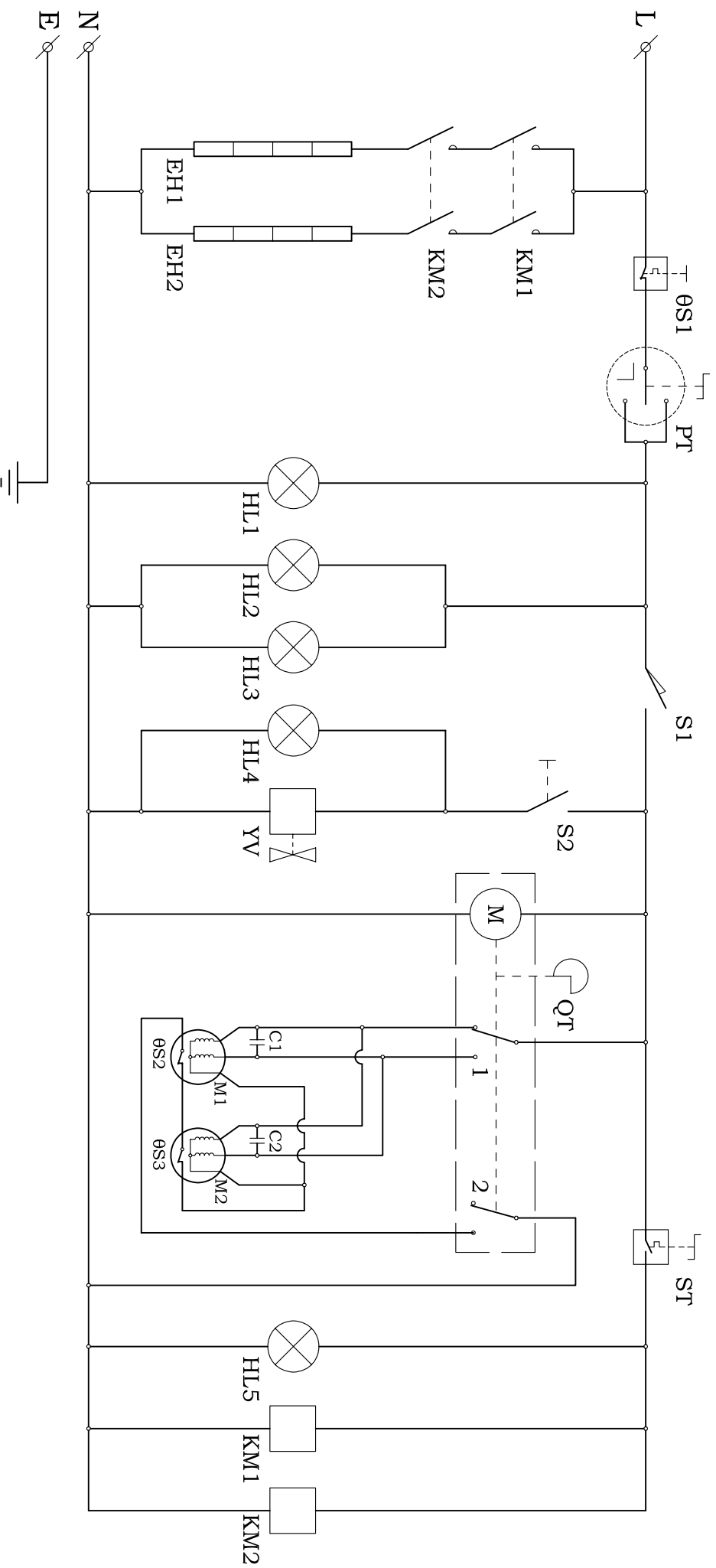

KM1, KM2--AC Contactor
 EH1, EH2--Heating Element
 θS1--Hi-Limit
 PT--Timer
 HL1--Power Indicator
 HL2, HL3--Chamber Light
 HL3--Spray Indicator
 YV--Solenoid Valve

S1--Travel Switch
 S2--Spray Switch
 QT--Controller
 C1, C2--Capacitor
 M1, M2--Motor
 S1, S2--Motor Fuse
 ST--Thermostat
 HL5--Heating Indicator