

TECHNISCHE DOKUMENTATION



KBS Gastrotechnik GmbH – Schoßbergstraße 26 – 65201 Wiesbaden

Asian Cooking - Wok Range

Gas - Wok table top

NGWT 3-55 SN



Due to continuous technical development, the image shown may not represent the latest design of the unit.

DESCRIPTION

Single burner table-top gas wok with a power rate of 11.5/13 kW. Compact design with a depth of 600 mm. Due to the versatile usage as a wok unit, open burner or pot cooker, it is suitable for various methods of Asian and Western cooking.

This wok is the perfect choice for catering-, street-food-, food-truck businesses and small kitchens.

Made of stainless steel AISI 304 with 1.2 mm strong top panel, burner with a cast iron pot holder and a stainless steel wok ring. Equipped with a drawer below the burner to collect grease, food debris and spillages for easy cleaning and enhanced hygienic.

OTHER AVAILABLE MODELS

- NGWT 7-55 SN
- NGTL 6-65 SO

MAIN FEATURES

- One atmospheric burner with a power rate of 11.5/13 kW (LPG/LNG).
- Cast iron potholder.
- Manual ignition.
- Equipped with pilot burner, safety thermo-couple, gas valve and and gas control knob.
- Grease collection drawer below the burner.
- CE certified unit.

CONSTRUCTION

- Unified body construction.
- Stainless steel top panel (1.2 mm), AISI 304 with orbital surface pattern.
- Front, back and side panels made of stainless steel AISI 430 with hairline surface pattern (1.2 mm).
- Height adjustable levelling legs.
- Type of installation: table-top.
- Frame, top and panels, all made of high-grade stainless steel.

INCLUDED ACCESSORIES

- Stainless steel wok ring Ø 290 mm.

OPTIONAL ACCESSORIES

- N/A

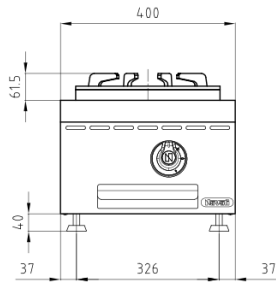
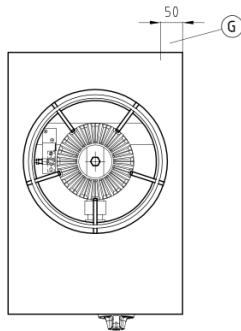
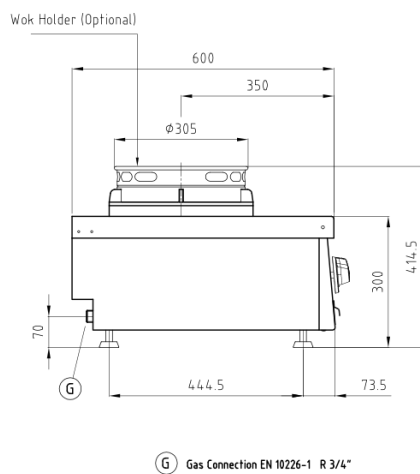
FRONT**TOP****SIDE**

*Overall dimension in mm

TECHNICAL DATA**External Dimensions**

Width	: 400 mm
Depth	: 600 mm
Height	: 300/361.5 mm

Cooking Surface

Wok burners	: $\phi 280$ mm
Soup burners	: N/A

Gas Power Rating

Heat input total	: LPG 11.5 kW, Natural Gas 13 kW
No. of burners	: 1
Control type	: High-low power control
Gas type options	: LPG G30, G31 Natural Gas G20, G25

Connections

Gas	: DN 20 (3/4")
Water	: N/A
Drain	: N/A

Heat & Steam Emissions

Direct heat emission	: LPG 2.87 kW , Natural Gas 3.25 kW
Latent heat emission	: LPG 1.73 kW , Natural Gas 1.95 kW
Steam emission	: LPG 3.05 kg/h , Natural Gas 3.45 kg/h

PACKAGING DATA

Width	: 430 mm
Depth	: 630 mm
Height	: 485 mm
Volume	: 0.13 m ³

WEIGHT

Net Weight	: 26 kg
Gross Weight	: 30 kg