

TECHNISCHE DOKUMENTATION



KBS Gastrotechnik GmbH – Schoßbergstraße 26 – 65201 Wiesbaden

Oriental Cooking - Wok Range

Gas - Wok Euro Line

NGER 15-60



Due to continuous technical development, the image shown may not represent the latest design of the unit.

DESCRIPTION

Gas wok with three burners, each with a power rate of 11.5/13 kW (LPG/LNG). Compact design with a depth of 600 mm. Due to the versatile usage as a wok unit, open burner or pot cooker, it is suitable for various methods of Oriental and Western cooking.

This wok is the perfect choice for any kitchen with a smaller footprint.

Made of stainless steel AISI 304 with a deep-drawn 3.2 mm strong, reinforced top panel, burner with a cast iron potholder and a stainless steel wok ring. Equipped with a drawer below each burner to collect grease, food debris and spillages for easy cleaning and enhanced hygienic.

OTHER AVAILABLE MODELS

- NGER 4-60
- NGER 9-60
- NGER 20-60

MAIN FEATURES

- Three atmospheric burners with a power rate of 11.5/13 kW (LPG/LNG) each.
- Cast iron potholder.
- Manual ignition.
- Equipped with pilot burners, safety thermocouples, gas valves and gas control knobs.
- Grease/food debris collection drawer below each burner.
- Suitable for wok-pan sizes Ø 14-18" (355-457 mm) and for pan sizes Ø 7-9" (178-230 mm).
- CE certified unit.

CONSTRUCTION

- Sturdy frame made of stainless steel AISI 430.
- Deep drawn, reinforced stainless steel top panel (3.2 mm), AISI 304 with hairline surface pattern.
- Front and side panels made of stainless steel AISI 304 with hairline surface pattern (1.0 mm).
- Backsplash made of stainless steel AISI 304 with hairline surface pattern (1.0 mm).
- Tubular, height adjustable (± 25 mm) stainless steel legs.
- Type of installation: free standing.
- Frame, top and panels, all made of high-grade stainless steel.

INCLUDED ACCESSORIES

- Stainless steel wok ring Ø 290 mm (3 pcs).

OPTIONAL ACCESSORIES

- N/A

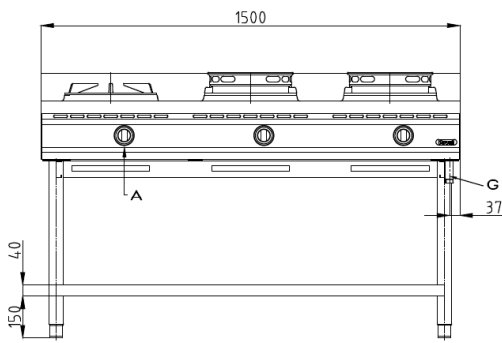
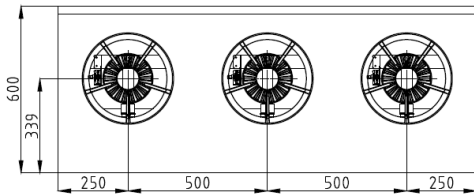
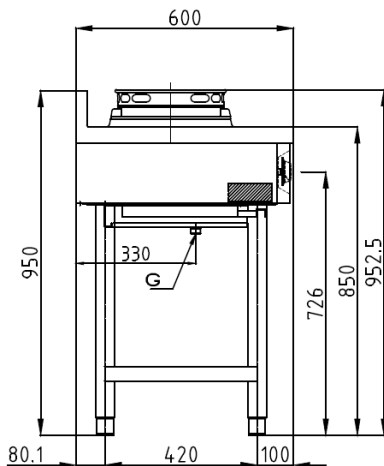
FRONT**TOP****SIDE**

*Overall dimension in mm

TECHNICAL DATA**External Dimensions**

Width	: 1500 mm
Depth	: 600 mm
Height	: 850/950 mm

Cooking Surface

Wok burners	: 3 x Ø 280 mm
Soup burners	: N/A

Gas Power Rating

Heat input total	: LPG 34.5 kW, LNG 39 kW
No. of burners	: 3
Control type	: High-low power control
Gas type options	: LPG G30, G31 LNG G20, G25

Connections

Gas	: DN 20 (3/4")
Water	: N/A
Drain	: N/A

Heat & Steam Emissions

Direct heat emission	: LPG 8.62 kW , LNG 9.75 kW
Latent heat emission	: LPG 5.18 kW , LNG 5.85 kW
Steam emission	: LPG 9.14 kg/h , LNG 10.34 kg/h

PACKAGING DATA

Width	: 1530 mm
Depth	: 630 mm
Height	: 545 mm
Volume	: 0.53 m ³

WEIGHT

Net Weight	: 85 kg
Gross Weight	: 111 kg