

TECHNISCHE DOKUMENTATION



KBS Gastrotechnik GmbH – Schoßbergstraße 26 – 65201 Wiesbaden

Oriental Cooking - Teppanyaki Griddle

Electric - Teppanyaki TP

TP 12/E Portable



Due to continuous technical development, the image shown may not represent the latest design of the unit.

DESCRIPTION

Electric Teppanyaki Griddle with uniform heating and accurate temperature control for superior hibachi-style cooking.

Two, individually controlled heating zones energized by Nayati SSS® die cast aluminium heating elements with a total of 11.7 kW connected load to ensure a stable and unfluctuating heating performance.

Griddles made of 20 mm thick, highly polished S355JR steel, which is designed to withstand the daily use of knives and spatulas. Mounted on a sturdy stainless steel frame construction with a height adjustable stainless steel legs. The removable top frame for the griddle and the large capacity grease container guarantees an excellent hygienic level.

OTHER AVAILABLE MODELS

- TP 12/E
- TP 15/E
- TP 15/E Portable

MAIN FEATURES

- High-efficient Nayati SSS® die cast aluminium heating elements with a total connected load of 11.7 kW.
- Thermostats with control knobs and function indication lights.
- Griddle plate, made of 20 mm polished S355 JR steel.
- Rectangular drain with a large stainless steel container to collect grease/ food debris.
- Hand-/condiment rail which accepts various numbers of GN 1/9 containers.
- CE certified unit.

CONSTRUCTION

Sturdy frame made of stainless steel AISI 430.

- Stainless steel top panel (1.5 mm), AISI 304 with orbital surface pattern.
- Front and side panels (1.0 mm) made of stainless steel AISI 304 with hairline surface pattern.
- Back panel (1.0 mm) made of stainless steel AISI 304 with hairline surface pattern.
- Height adjustable stainless steel legs.
- Types of installations: table-top.
- Frame, top and panels, all made of high-grade stainless steel.

INCLUDED ACCESSORIES

- N/A

OPTIONAL ACCESSORIES

- N/A

PT. NAYATI INDONESIA

www.nayati.com

Nayati reserves the right to make product alterations and or price adjustments at any time and can not be held responsible for any printing errors or omissions.

FRONT

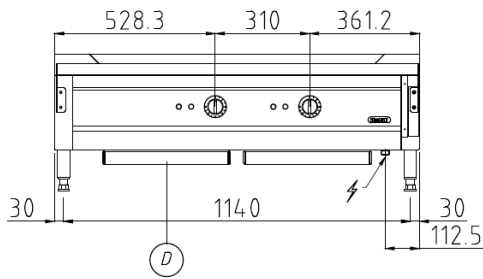

TOP

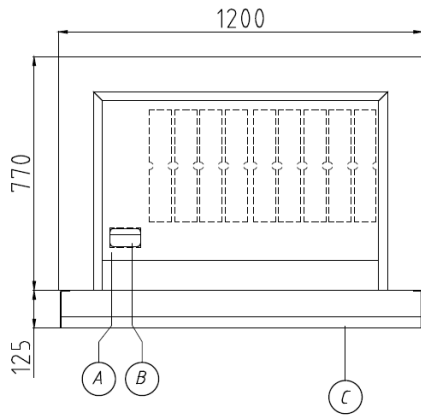

SIDE

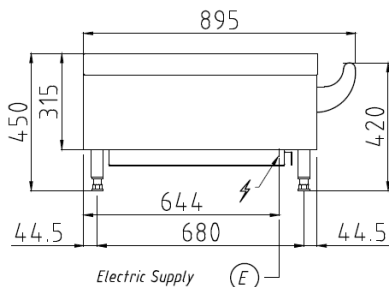

*Overall dimension in mm

TECHNICAL DATA

External Dimensions

Width : 1200 mm
 Depth : 770/895 mm
 Height : 450 mm

Cooking Surface

Cooking zones : 960 x 550 mm
 Heating zones : 2
 Control type : Modulating temperature control

Electrical Supply Data

Total connected load : 11.7 kW
 Voltage : 400V, 3NPE AC /50-60Hz
 Recommended fuse : 20 A (slow)

Connections

Water : N/A
 Drain : N/A

Heat & Steam Emissions

Direct heat emission : 3.86 kW
 Latent heat emission : 4.68 kW
 Steam emission : 6.88 kg/h

PACKAGING DATA

Width : 1230 mm
 Depth : 925 mm
 Height : 570 mm
 Volume : 0.65 m³

WEIGHT

Net Weight : 168 kg
 Gross Weight : 197 kg